

Mitered Borders

1. Fold the quilt top in half lengthwise. Place a straight pin at each fold to mark the center. Fold the quilt top in half widthwise and pin at each fold. Fold each border strip in half and pin at the folds.

2. Center the long border strips on the opposite long sides of the quilt RST by matching pinned center points. Repin layers together. Sew the border to the quilt top **starting and stopping 1/4" away from the edges of the quilt top**. Press toward darker fabric.

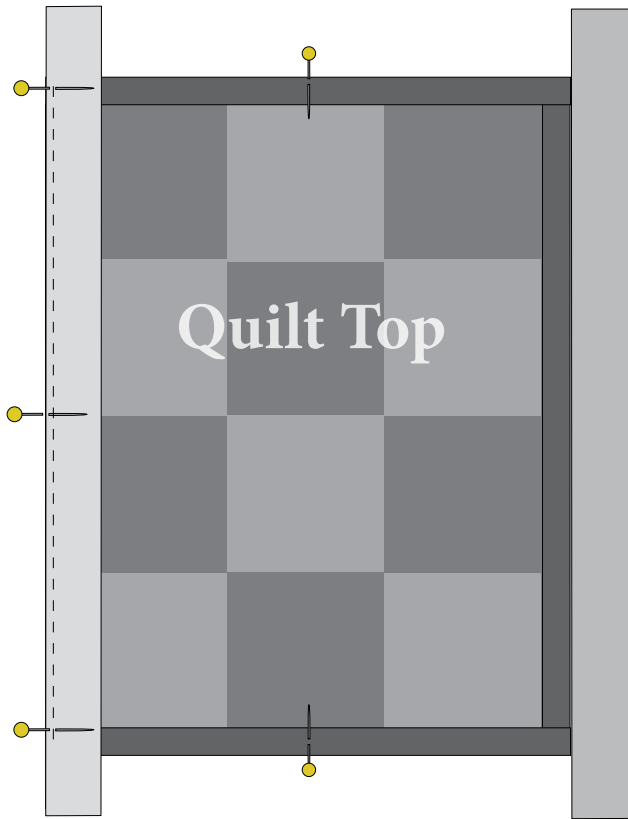

3. Place a short border strip onto the quilt top RST. Match the center points and repin.

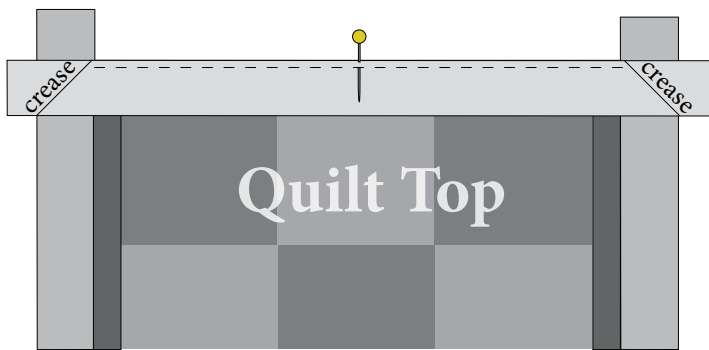

4. Press the ends of each short border strip at a 45° angle. Sew the short border strips to the top and bottom of the quilt. **Start and stop the stitches 1/4" away from the edges of the pieced top.**

5. Bring the short edges of the border strips together.

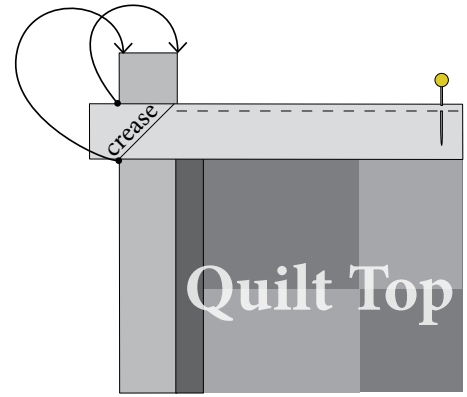

6. Sew along the pressed creases. Press open. Trim excess fabric.

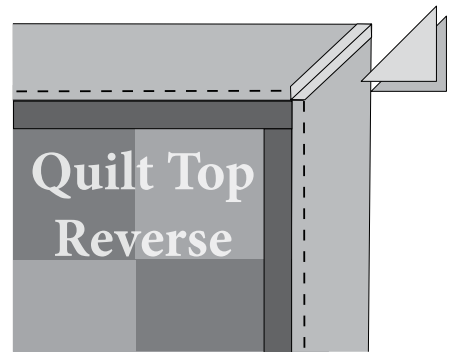

7. Repeat the process for the remaining corners.

