



Pretty Pieces Dress

Finished Project Size: 2T to 4T

Supplies Needed

- 1 Bundle (5 - 18" x 21" pcs.)
- 1 Coordinating toddler t-shirt
- 3 Coordinating buttons
- Coordinating thread
- 1/2 yd. Ribbon - 3/8"
- Rotary cutter, mat, & acrylic ruler
- Pinking shears (optional)
- Sewing machine and basic sewing supplies
- Iron
- Pencil

Instructions

Before you begin: Pre-wash and press bundle fabrics and t-shirt. Read all instructions before beginning project. Use a 1/2" seam allowance and sew fabrics with right sides together unless otherwise noted. Zigzag, serge, or pink all seams to finish raw edges.

Cutting (width dimension listed first)

Fabrics A - D: 2 - 6" x 17" (skirt panels)
Fabric E: 8 - 2" x 17" (panel inserts)

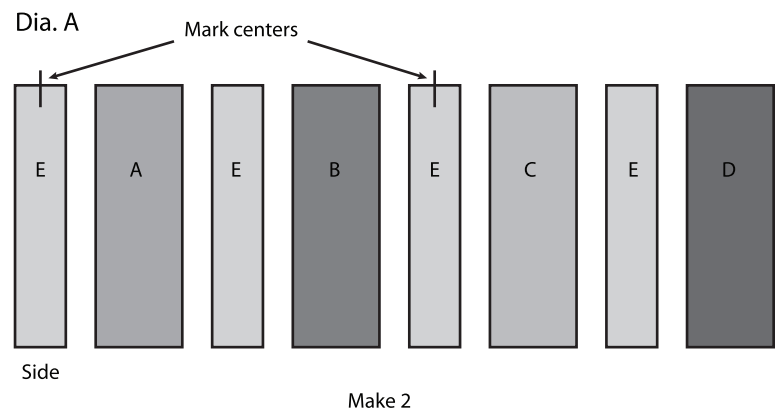

Care Instructions: Wash in cool water, tumble dry low heat.



Piecing

1. Lay out two sets of skirt panels and panel inserts for skirt front and back; sew panels together (Dia. A).
2. On wrong side of fabric, use pencil to mark center top edges of the first and third panel inserts of each set to indicate sides and centers (Dia. A).
3. Sew skirt front and back together along sides. Press all seams toward the skirt panels.
4. Use a long machine stitch to sew two rows of stitching 1/4" apart along top edge of skirt for gathering. Start and stop sewing at side seams, leaving thread tails for gathering. (*Note: The top edge has markings on inserts.*)
5. Measure 2 1/2" below armhole seams of the t-shirt and cut off bottom edge (Dia. B). Fold t-shirt in half, matching side seams; mark front and back centers with pins.
6. Place bottom edge of t-shirt inside top edge of skirt with raw edges together (Dia. C). Match side and center marks of skirt to t-shirt side seams and center front and back; pin.
7. Pull thread tails to gather top edge of skirt to match the bottom edge of the t-shirt. Adjust gathers evenly and pin in place. Sew skirt to t-shirt and press seam toward the t-shirt. Turn dress right side out.

Finishing

8. Try dress on child and mark desired dress length. Add 1" for hem and trim off any excess. Fold raw edge under 1/2" and press; then fold under 1/2" again and press. Topstitch to hem.
9. Fold t-shirt in half, matching side seams; mark center front near neckline with a pin. Measure about 1 1/2" from neck ribbing at the center and mark with pin. Center and stack buttons on this mark (Dia. D). Sew through buttons to attach.
10. Tie ribbon into a bow and hand stitch under buttons. Trim ends to desired length.

Dia. B

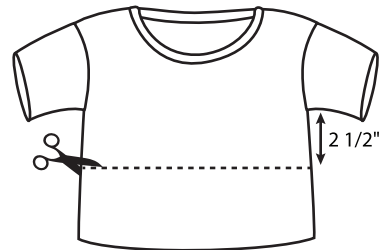

Dia. C

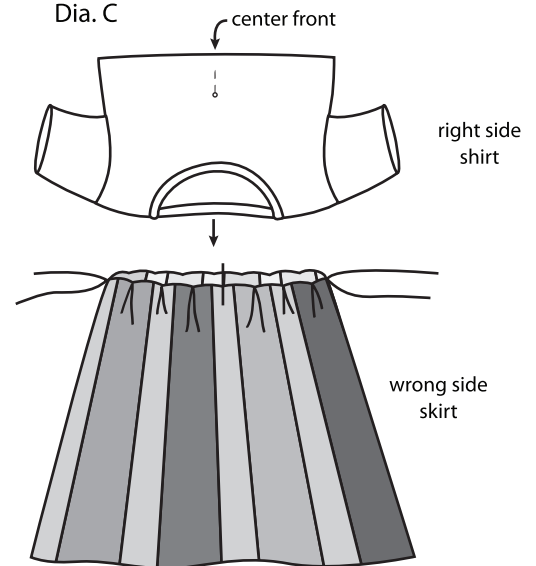

Dia. D

