

BBW series

High speed, Single needle, Compound feed and walking foot, Lockstitch sewing machine with automatic thread trimmer, Automatic backtacking, Automatic presser foot lift, Climbing device and dual stitching device

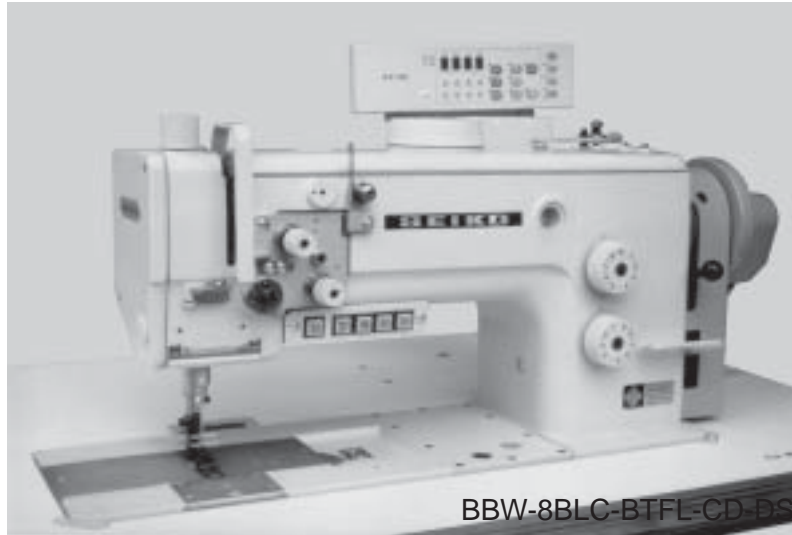

BBW-8BLC-BTFL-CD-DS

Variety



BBW-8BL

Compound feed and walking foot, reverse stitch



BBW-8BLC

Compound feed and walking foot, reverse stitch, thread trimmer



BBW-8BLC-BTFL-CD-DS

Compound feed and walking foot, reverse stitch, thread trimmer, automatic back tack, automatic presser foot lift, climbing device, dual stitching device

Applications

For sewing medium to heavy weight materials such as leather, vinyl, synthetics and laminated and coated materials

Suitable for sewing such as automobile upholstery tarpaulins, covers, awnings, tents, umbrellas handbags, luggage, travelware accessories, sports and camping equipment and wearing apparel outdoor clothing.



Features

Longer stitch length quiet sewing operation

- * Max. 9mm for both forward and reverse feed stitching.
- * Compound feed and walking foot for positive stitching formation.
- * Link-type thread take-up lever mechanism for high speed and quiet sewing operation.

BBW series are equipped with a large vertical axis hook(1.6 times)

- * Large capacity hook minimizes the time to replace the bobbin thread in stitching of thick thread.
- * This hook promote highly efficient operation by reducing the frequency of bobbin thread replacement.

Safety device

- * Safety device prevents damage to hook and thread handling parts caused by thread jamming.

Reliable thread trimming device

- * Reliable automatic thread trimming device securely cuts up to #5 thread is equipped. (BBW-8BLC only)

One touch switchover for two different stitch lengths (DS device)

- * Variety sewing materials such as steps, curves, uneven thickness can be performed by one touch switchover setting two different stitch lengths. The efficient work and beautiful finishes will be obtained. (BBW-8BLC only)

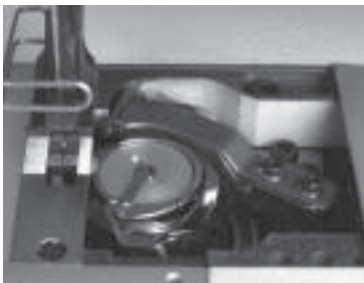

1.6 times large capacity hook and reliable thread trimming device



Safety device



One touch switchover for two different stitch lengths (DS Device)

Built-in bobbin winder

- * Built-in bobbin winder makes it possible to wind the bobbin thread during sewing operation.

Wide working space

- * 300 mm working space, from the needle to the sewing machine arm, makes sewing works easy to handle heavy weight and even large materials.

Large clearance under presser foot

- * The clearance under the presser foot (16mm), makes it easy to put heavy weight materials in and out.

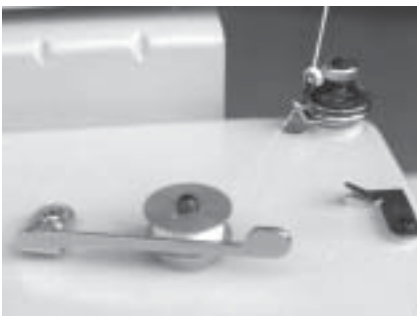

Built-in bobbin winder

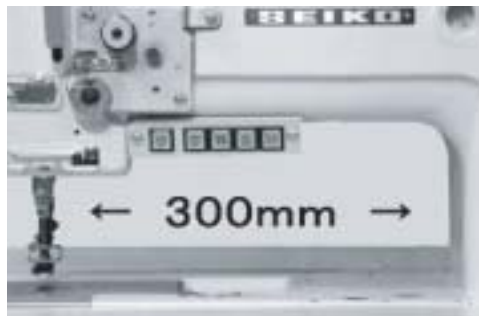

Wide working space



The clearance under the presser foot (16mm)

Presser bar lifter

- * As the presser bar lifter is located on the right side of the sewing machine, just above the reverse lever, sufficient space is kept behind the presser foot. Due to this, smooth sewing operation even rolled-up materials is guaranteed.



Presser bar lifter

BBW series

Simple setting for alternating presser foot movement

* Alternating presser foot movement between inner foot and outer foot can be changed simply by the easy-to-handle dial located at the top of the sewing machine.

* Once the alternating movements have been set, the sewing speed is automatically controlled to the optimum speed so that stable sewing is maintained. (-8BLC-BTFL-CD-DS only)

Smooth stitching on step section (CD device)

* The presser foot movement can be changed to maximum momentum (7mm) by button. Uneven thickness of materials can be smoothly performed changing the movement right before the uneven point. (-8BLC-BTFL-CD-DS only)

5 operational switches improve working efficiency

* 5 switch buttons are panelled on the convenient positions improve the efficient works. (-8BLC-BTFL-CD-DS only)



Simple setting for alternating presser foot movement

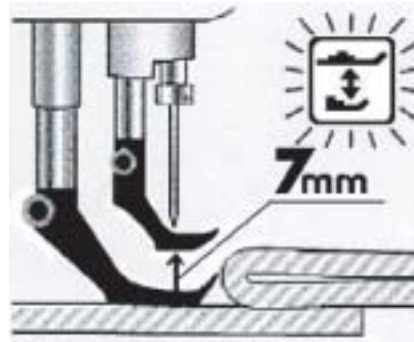

Smooth stitching on step section (CD device)



5 operational switches



Quick reverse switch

* During Pressing the switch, sewing machine performs reverse stitching.



Walking foot movement change switch

* By pressing the switch, the amount of walking foot movement is changed. When the indicating light is on, the movement is set at the maximum (7mm). When the indicating light is off, the movement is set by the walking foot movement dial.



Auto backtack select switch

* In case of auto backtacking is set beforehand, by pressing the switch, the auto backtacking is released. In case of auto backtacking is not set, by pressing the switch, the auto backtacking performs. (Both are effective only at the first time.)



Half stitch switch

* When sewing machine stops, the needle position can be changed by pressing the switch at up position or down position as desired.



Stitch length change switch

* By pressing the switch, two different stitch lengths set beforehand can be changed one to the other. When the indicating light is on, the shorter stitch length is available, while the longer stitch is available when the light is off.

Specifications (BBW-)

Variety	BBW-8BL	BBW-8BLC	BBW-8BLC-BTFL-CD-DS
Number of needle	Single needle		
Max. sewing speed	3,500 s.p.m. (Refer to list below)		
Max.stitch length	9mm (Forward / Reverse)		
Clearance under presser foot	9mm (by hand) 16mm (by knee)		9mm (by hand) 16mm (by automatic foot lifter)
Needle bar stroke	34mm		
Needle	135 x 17 Nm110 ~ Nm200 (Nm160) or DP x 17 # 18 ~ # 25 (# 23)		
Thread	# 30 ~ # 5 (Standard # 8)		
Hook	Large vertical axis hook (1.6 times)		
Thread length after trimming	-	27mm	
Thread take up lever	Link type		
Amount of walking foot movement	1~6.5mm		1~7mm
Walking foot movement change switch	Dial type		
Bobbin winder	Built-in type located at the top of the sewing machine		
Auto presser foot lifting device	-		Pneumatic
Walking foot movement change device	-		Pneumatic
Safety device	Standard		
Lubrication	Automatic lubrication type		
Bed size / Working space	567mm x 177mm / 300mm x 120mm		
Net weight (Head only)	48.5Kg	50Kg	51Kg
Motor	Clutch motor		AC Servo motor

NOTE (1) Speed depends on threads, materials and type of operation
 (2) Specifications subject to change without notice

Sewing speed range (BBW-8BLC-BTFL-CD-DS)

Amount of walking foot movement	Stitch length	
	6mm and less	6mm~9mm
1 mm~2 mm	3500 s.p.m	2000 s.p.m.
3 mm	3000 s.p.m.	
4 mm	2500 s.p.m.	
5 mm ~ 7 mm	2000 s.p.m.	

BBW-

	8BLC	8BLC-BTFL-CD-DS
Thread trimming (C)		
Quick reverse feed (BT)	-	
Auto presser foot lifting (FL)	-	
Walking foot movement changeover (CD)	-	
Stitch length change (DS)	-	



SEIKO SEWING MACHINE CO., LTD.

2-13-6, Sakaecho, Funabashi-shi
 Chiba Prefecture, 273-0018, Japan

Phone : +81-47-420-3561 (Overseas dept.)

Fax : +81-47-420-3560

E-mail : export@seiko-sewing.co.jp

<http://www.seiko-sewing.co.jp/>