

SALEM CITY POWER  
ELECTRICAL REQUIREMENTS  
& STANDARDS MANUAL

SALEM CITY  
POWER DEPARTMENT

# SALEM CITY POWER ELECTRICAL REQUIREMENTS & STANDARDS MANUAL TABLE OF CONTENTS

<b>Section 1 – General Requirements</b>	
Purpose.....	1.1
Codes and Ordinances.....	1.1
Changes or Conflicts in Requirements and Guidelines .....	1.1
Application for Service .....	1.2
Types of Service Furnished .....	1.2
Overhead Service .....	1.2
Underground Service .....	1.2
Approval for Service.....	1.2
Permanent Service Connection .....	1.3
Seals .....	1.3
Work Activity Near High Voltage Overhead Power Lines .....	1.3
Underground Primary/Secondary System Requirements	
Of Subdivision And Commercial Areas .....	1.4
Application.....	1.4
<b>Section 2 – Trenching and Conduit</b>	
Trenching .....	2.1
Call Before You Dig .....	2.1
Depth.....	2.1
Width.....	2.1
Backfill.....	2.1
Joint Use.....	2.2
System Joint Use Trench .....	2.3
Conduit.....	2.4
2” Conduit Requirements.....	2.4
<b>Section 3 – Residential Service</b>	
Side View.....	3.1
Front View .....	3.2
<b>Section 4 – Secondary Junction Box</b>	
Secondary Junction Box .....	4.1



## SALEM CITY POWER ELECTRICAL REQUIREMENTS & STANDARDS MANUAL TABLE OF CONTENTS

TABLE OF CONTENTS 1
ELECTRICAL STANDARDS
SCALE: NONE
DATE: 8.29.07
REV:
REV DATE:

Section 5 – Pad Mounted Transformer

- Single-Phase Transformer Pad or Secondary Junction Box Location  
With Planter and Sidewalk.....5.1
- Single-Phase Transformer Pad or Secondary Junction Box Location  
With Sidewalk and Planter.....5.2
- Single-Phase Transformer Pad or Secondary Junction Box Location  
With Sidewalk and No Planter.....5.3
- Single-Phase and Three-Phase Pad Mounted Transformer  
Clearances .....5.4
- Equipment Erosion Prevention .....5.5
- Single-Phase Pad Mounted Transformer .....5.6
- Three-Phase Transformer Concrete Pad Without CT Rack.....5.7
- Three-Phase Transformer Pad With Metering Station.....5.8

Section 6 – Street Lighting

- General .....6.1
- Street Light Layouts.....6.1
- Point(s) of Delivery for Decorative Lighting.....6.2
- Conduit for Salem City Power  
Standard and Decorative Street Lights .....6.3
- Salem City Power Standard Street Lights.....6.3
- Decorative Street Lights .....6.3
- Street Lighting Conduit Requirements .....6.3
- Typical Street Lighting Layout.....6.4
- Street Light Wiring .....6.5

Section 7 – Sectionalizers and Switches

- Conduit placement for Sectionalizers .....7.1
- Conduit placement for Switches .....7.1



**SALEM CITY POWER  
ELECTRICAL REQUIREMENTS  
& STANDARDS MANUAL  
TABLE OF CONTENTS**

TABLE OF CONTENTS 2
ELECTRICAL STANDARDS
SCALE: NONE
DATE: 8.29.07
REV:
REV DATE:

# GENERAL REQUIREMENTS

## PURPOSE

This section was prepared to aid developers, contractors, engineers and customers in establishing electric service for new and remodeled structures. We recognize that you may require personal assistance from our staff, and we encourage you to contact us by calling Salem City Power to discuss electric service requirements with us. It is the desire of Salem Power, and the local electrical code enforcing authority to provide you, the Customer (developers, contractors, owners, etc.) with high quality, safe electric service.

In order to avoid unnecessary repetition, the "Power Department" as used in the following pages shall mean Salem City Power Department.

The requirements are intended to apply to new developments.

As a general rule, if the matter in question is not presented herein, then it is not allowed unless approved by the City's power department.

Any power required for private use (i.e. light, sprinkler, etc.) shall be metered.

## CODES AND ORDINANCES

It is necessary that the construction of new or remodeled installations conform to applicable provisions of the National Electrical Code (NEC), National Electrical Safety Code (NESC), and State of Utah Electrical Service Regulations, as well as City and County ordinances and codes. This includes OSHA rules both during construction and maintenance.

## CHANGES OR CONFLICTS IN REQUIREMENTS AND GUIDELINES

Some of the information in this section is based on the aforementioned governmental codes and ordinances as well as Salem City Power specific requirements as stated herein. These requirements and guidelines are issued with the intent of complying with all applicable codes, ordinances, regulations, and tariffs; however, in the case of conflict, the appropriate regulation, tariff, code, or ordinance will supersede the interpretation offered in this manual. In addition, these requirements are subject to change in the event that the governing codes, ordinances, regulations, or tariffs are changed. The Power Department should be consulted in case of doubt on the applicability of any item.

The phrase "consult Power Department" as used in this manual shall mean a consultation with Salem City Power Department Superintendent is to be made for each and every installation or project.

**SALEM CITY POWER  
ELECTRICAL REQUIREMENTS  
& STANDARDS MANUAL  
GENERAL REQUIREMENTS**

ELECTRIC 1.1
GENERAL REQUIREMENTS
SCALE: NONE
DATE: 8.29.07
REV:
REV DATE:

## APPLICATION FOR SERVICE

It is important that the Power Department office be provided as early as possible with accurate load information and the date when the Customer will require service, so all necessary arrangements for the service may be completed. Request for service to large residential developments normally require 60 days advance planning by the Power Department in order to serve the load. Installations requiring transformers or other equipment not in stock may require six months lead time or more.

The Power Department is available to provide advice on service requirements and related problems relative to electric energy utilization for new, existing, and reconstructed installations. The Developer will be held liable for any damage to Power Department equipment.

When conditions are encountered during construction that require changes in the initial, agreed upon service arrangements, the Power Department must be consulted so mutually satisfactory alternative arrangements can be made. Adequate notice must be given to the Power Department and approval granted regarding changes or additions.

## TYPES OF SERVICE FURNISHED

The electric service available is 60 hertz (cycles), alternating current, single or three-phase. The secondary voltages and connections available are given below:

### Overhead Service (Not Included)

### Underground Service

- Single-phase, 120/240 volt, three-wire, grounded
- Three-phase, 208Y/120 volt, four-wire, grounded, wye
- Three-phase, 480Y/277 volt, four-wire, grounded, wye

The nominal primary voltage of Salem City's power distribution system may differ from one service area to another. Under certain conditions, primary delivery will be supplied at the distribution voltage standard for the location at which it is requested.

## APPROVAL FOR SERVICE

It is required that an electrical installation be approved by the electrical inspection authority having jurisdiction and by the Power Department, as stated herein, before it can be energized by the Power Department. The service will be energized by the Power Department only after all service requirements and inspections have been met.

	<b>SALEM CITY POWER ELECTRICAL REQUIREMENTS &amp; STANDARDS MANUAL GENERAL REQUIREMENTS</b>	ELECTRIC 1.2
		GENERAL REQUIREMENTS
		SCALE: NONE
		DATE: 8.29.07
		REV:
		REV DATE:

## **PERMANENT SERVICE CONNECTION**

Only authorized Power Department employees shall make the permanent (or temporary) connection or disconnection of the Power Departments' electric service to a building, structure or subdivision interconnections.

## **SEALS**

The purpose of seals by the Power Department on meters and associated service equipment is to prevent injury and/or tampering.

Under normal circumstances, seals are not to be removed except by the Power Department. If an emergency should require seal removal (only by authorized electrical contractors) without prior notification, the Power Department must be notified as soon as possible, so the installation can be inspected and the seal replaced. When this occurs, the party removing the seal shall accept all liability for damage or alteration to equipment, injury to persons or property, and loss of revenue to the Power Department from the time the seal is removed until 72 hours after the Power Department has been notified that the equipment is ready to be re-sealed.

## **WORK ACTIVITY NEAR HIGH VOLTAGE OVERHEAD POWER LINES**

As set forth in Section 54-8c-1 through 54-8c-7 of the Utah Code, no person or thing may be brought within 10 feet of any high voltage overhead line unless:

The responsible party has notified the Power Department or Utility operating the high voltage line of the intended activity; and

The responsible party and the Power Department or Utility have completed mutually satisfactory safety precautions for the activity; and

The responsible party has made prior arrangements to pay the Power Department or Utility for the mutually satisfactory safety precautions (if applicable).

The Power Department recommends a minimum of 3 business day's notice be given before any work near its lines is scheduled to begin.

NOTE: The National Electrical Safety Code requires that homes, buildings, bridges, signs, antennas, etc. have sufficient horizontal and vertical clearance to overhead power lines. Consult the Power Department for applicable distances.

	<b>SALEM CITY POWER ELECTRICAL REQUIREMENTS &amp; STANDARDS MANUAL GENERAL REQUIREMENTS</b>	ELECTRIC 1.3
		GENERAL REQUIREMENTS
		SCALE: NONE
		DATE: 8.29.07
		REV:
		REV DATE:

## **UNDERGROUND PRIMARY/SECONDARY SYSTEM REQUIREMENTS OF SUBDIVISION AND COMMERCIAL AREAS**

The intent of this policy is to set forth the Developer's installation requirements and to outline specific installation standards. Along with requirements indicated in this section applicable requirements as indicated in other sections of this document apply to commercial and residential developments.

Where a development within the service area of the City is to be subdivided into residential or commercial lots and has been approved by the appropriate Planning and Zoning Boards, the electrical distribution system will be installed underground in accordance with the City's connection fee and line extension policy. The subdivision Developer shall provide the City with the easements necessary for the most efficient installation of the required distribution system. All electrical systems installed by the Developer shall be front lot construction unless otherwise approved by the Salem City Power Department.

The following subsections serve as a guide for specific requirements of commercial and residential developments; however, the developer is responsible for coordinating with the Power Department to insure that the intents of this policy are met.

### **APPLICATION**

For commercial, industrial, residential subdivisions, mobile home parks, and apartment complex applications, the request for service shall include a plot plan indicating equipment size. Commercial or industrial plot plans should show preferred service and meter locations and a single-line diagram of the overall electrical system. The request must show all load information, for commercial developments load information should include lighting, receptacle, water heating, cooking, electric heat, air conditioning, and motor loads, plus sufficient information on equipment operations to allow the kilowatt demand of the load to be estimated. The Power Department shall review the drawings and return the drawing set marked "Approved" or "Unapproved" with an indication of required changes.

	<b>SALEM CITY POWER ELECTRICAL REQUIREMENTS &amp; STANDARDS MANUAL GENERAL REQUIREMENTS</b>	ELECTRIC 1.4
		GENERAL REQUIREMENTS
		SCALE: NONE
		DATE: 8.29.07
		REV:
		REV DATE:

# Trenching and Conduit

## TRENCHING

The developer is to provide the trench for all required conduit systems and, following installation of the conduit by the Developer, backfill to meet Power Department requirements. The Power Department, under the terms of the City's Line Extension policy, will install both primary (medium voltage 12.47 kV or 4.16 kV) and secondary cables (below 480 volts).

To assure the final grade has been established, the trenching will be started after the curbs and gutters have been installed unless approved by the Salem City Power Department.

### Call Before You Dig

Utah Law Section 54-8A-1 through 54-8A-11 requires the Blue Stakes One Call Location Center be notified at least two working days prior to excavation. The excavation must not be started until locations have been made.

### Depth

SEE CHART ON E2.3 FOR TRENCHING DEPTHS. The property owner is responsible at their own cost to insure that proper burial depth clearance listed below is maintained even after excavation of the property. Any questions on impaired burial depths should be immediately brought to the attention of the Power Department. Under certain conditions, with prior Power Department approval, cable/conduit systems may be buried with less cover provided that mechanical protection is installed by the Developer to the Power Departments specifications.

### Width

All trenches meet OSHA requirements. Primary/secondary combined trenches shall be a minimum of 18 inches wide at the bottom. Trenches 12 inches wide will be approved for a single service only.

### Backfill

The developer will be responsible for backfilling trenches he provides. The Developer must provide 10" of sand to be placed on top of conduits and shall have red warning tape on top of sand. Where trenches cross structural fill, typical of road crossings, the trench backfill shall consist of like kind structural fill. All primary trenches and all road crossings trenches (including secondary) shall be compacted to 95% compaction of the maximum dry density as determined by ASHTO T-99 (standard). All primary and secondary conduit systems shall have placement of red warning tape 6" below final grade. The tape shall be of the type specific for the application.

	<b>SALEM CITY POWER ELECTRICAL REQUIREMENTS &amp; STANDARDS MANUAL TRENCHING AND CONDUIT</b>	ELECTRIC 2.1
		TRENCHING AND CONDUIT
		SCALE: NONE
		DATE: 8.29.07
		REV:
		REV DATE:



## Joint Use

Typically, joint use between other utilities of power department trenches is not allowed unless approved by the Power Department. Any joint use between telephone, TV, and other electrical communication cables must be pre-approved by the Power Department and installed in accordance with the Power Department specifications. The Power Department normally will not install electrical cables in a common trench with non-electric utilities such as water, gas, and sewer, unless unusual conditions such as adverse soil or route restrictions exist. All such installations require the prior approval of the Power Department.

	<b>SALEM CITY POWER ELECTRICAL REQUIREMENTS &amp; STANDARDS MANUAL TRENCHING AND CONDUIT</b>	ELECTRIC 2.2
		TRENCHING AND CONDUIT
		SCALE: NONE
		DATE: 8.29.07
		REV:
		REV DATE:

# System Joint Use Trench

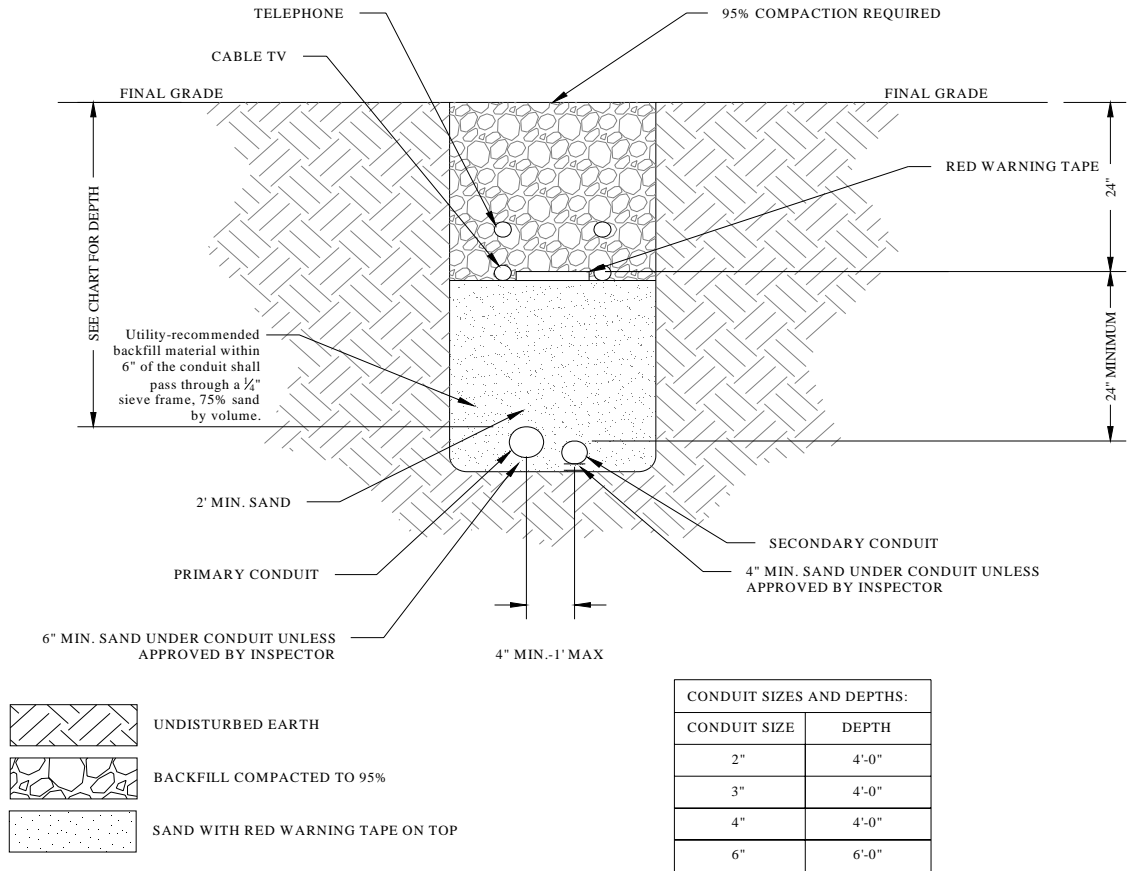

Figure 1 – Trench Cross Section

## SALEM CITY POWER ELECTRICAL REQUIREMENTS & STANDARDS MANUAL TRENCHING AND CONDUIT

ELECTRIC 2.3
TRENCHING AND CONDUIT
SCALE: NONE
DATE: 8.29.07
REV:
REV DATE:

## CONDUIT

The Power Department requires the use of conduit for all underground primary and secondary cable installations, including lighting circuits. Rigid galvanized steel, IMC and gray electrical grade PVC schedule 40 (underground only) conduit are acceptable materials for conduits installed by the Customer.

All 90-degree bends are to be a minimum of 15" radius for 2" pipe, 18" radius for 3" pipe, 30" radius for 4" pipe, and 36" radius for 6" pipe. All primary elbows are to be PVC for 2", 3" and 4" conduits, steel elbows for 6" conduit.

All conduits shall be terminated at the open end with plastic bushings.

All underground metallic conduit must be tape wrapped with suitable tape for the application.

Residential primary conduit sizes must be three (3) inch. Secondary conduit size shall be three (3) inches from transformers to junction domes and two (2) inches from transformer or dome or transformer to resident.

All conduits end points shall be sealed or taped to prevent debris from plugging the conduit and future use (1" PVC painted red). The Developer shall be responsible for cleaning conduits if the Power Department is unable to install or pull the service cable.

Along with conduits extending to secondary junction boxes, each transformer pad and secondary box shall have ten (10) foot conduit stub outs for interconnection to adjacent homes.

Prior to backfilling, the Developer must notify the Power Department for an inspection, following the inspection the Power Department shall issue a notice to proceed slip, allowing backfilling.

### 2" CONDUIT REQUIREMENTS

Along with conduit requirements for the installation of power cables the Developer must provide a 2" conduit system. The conduit system shall consist of 1- two (2) inch gray PVC schedule 40 conduit and shall parallel the primary power system and to the secondary junction boxes. All applicable requirements pertaining to the installation of the power conduit system apply to 2" conduit system.

	<b>SALEM CITY POWER ELECTRICAL REQUIREMENTS &amp; STANDARDS MANUAL TRENCHING AND CONDUIT</b>	ELECTRIC 2.4
		TRENCHING AND CONDUIT
		SCALE: NONE
		DATE: 8.29.07
		REV:
		REV DATE:

# Residential Services

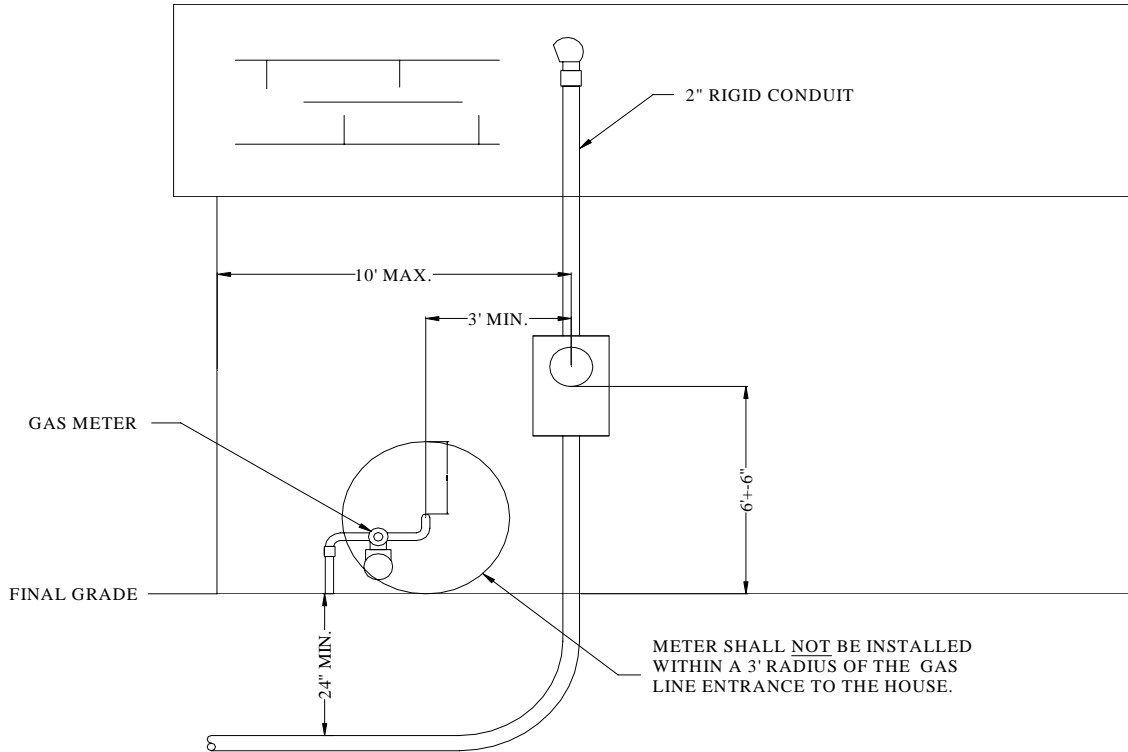

See sheet E3.2 for front view  
Residential Services

**SALEM CITY POWER  
ELECTRICAL REQUIREMENTS  
& STANDARDS MANUAL  
RESIDENTIAL SERVICES**

ELECTRIC 3.1
RESIDENTIAL SERVICES
SCALE: NONE
DATE: 8.29.07
REV:
REV DATE:

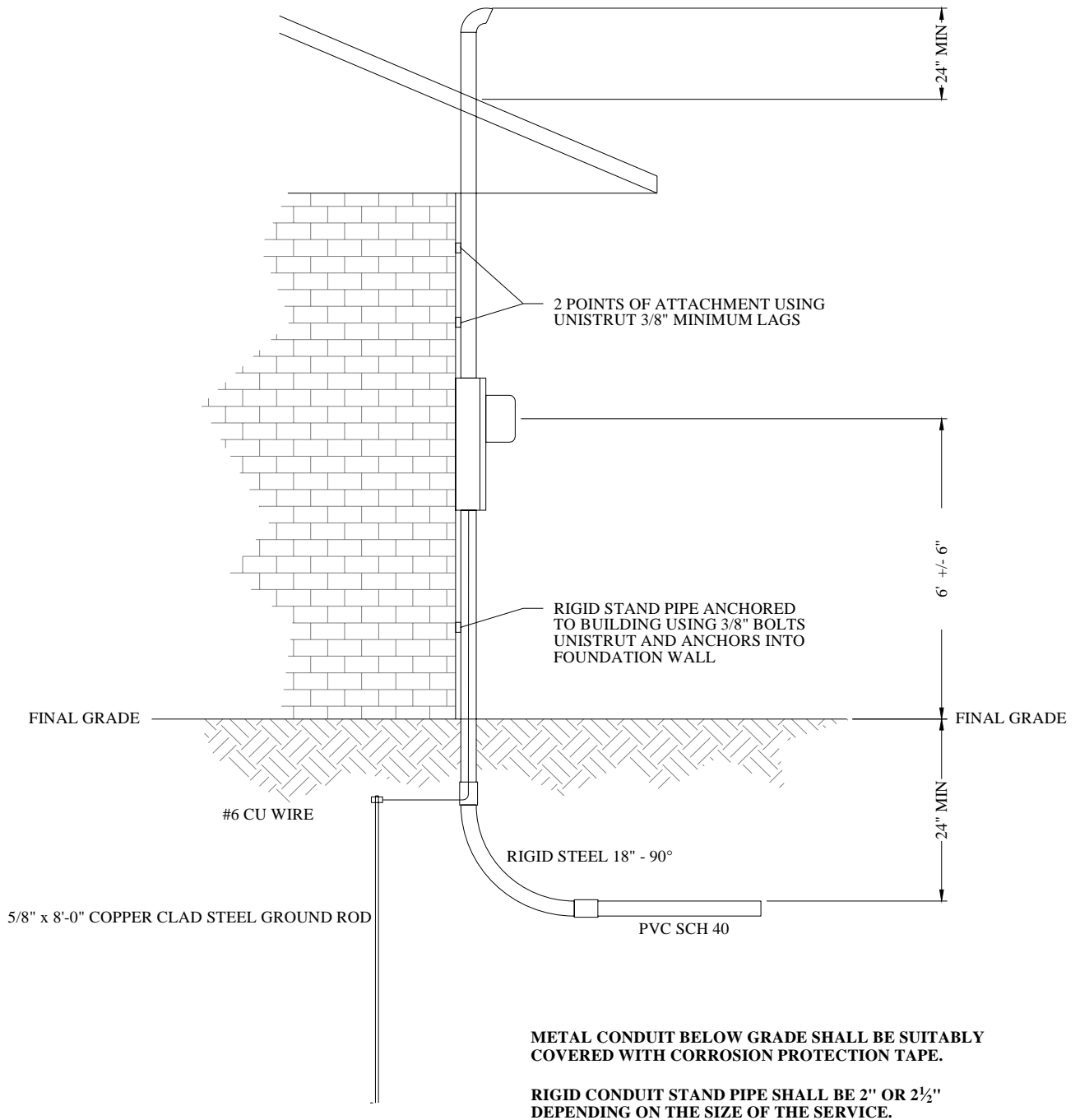

See sheet E3.1 for side view

**SALEM CITY POWER  
ELECTRICAL REQUIREMENTS  
& STANDARDS MANUAL  
RESIDENTIAL SERVICES**

ELECTRIC 3.2
RESIDENTIAL SERVICES
SCALE: NONE
DATE: 8.29.07
REV:
REV DATE:

# Secondary Junction Box

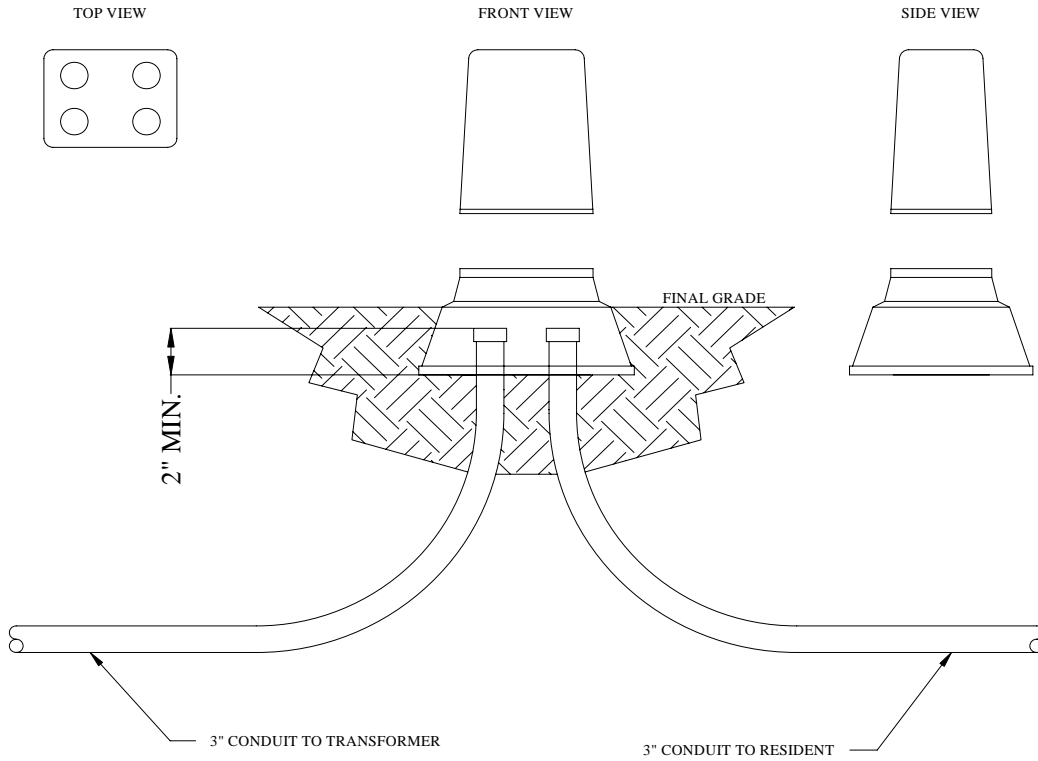

**Notes:**

1. Salem City Power to provide developer secondary junction boxes with 3" stub outs on request.
2. Developer shall provide minimum spacing between conduits.
3. Developer to seal all conduit ends with permanent caps to prevent plugging.
4. Developer is responsible for trenching and back filling.

**SALEM CITY POWER  
ELECTRICAL REQUIREMENTS  
& STANDARDS MANUAL  
SECONDARY JUNCTION BOX**

ELECTRIC 4.1
SECONDARY JUNCTION BOX
SCALE: NONE
DATE 8.29.07
REV:
REV DATE:

# Single-Phase Transformer Pad or Secondary Junction Box Location with Planter and Sidewalk

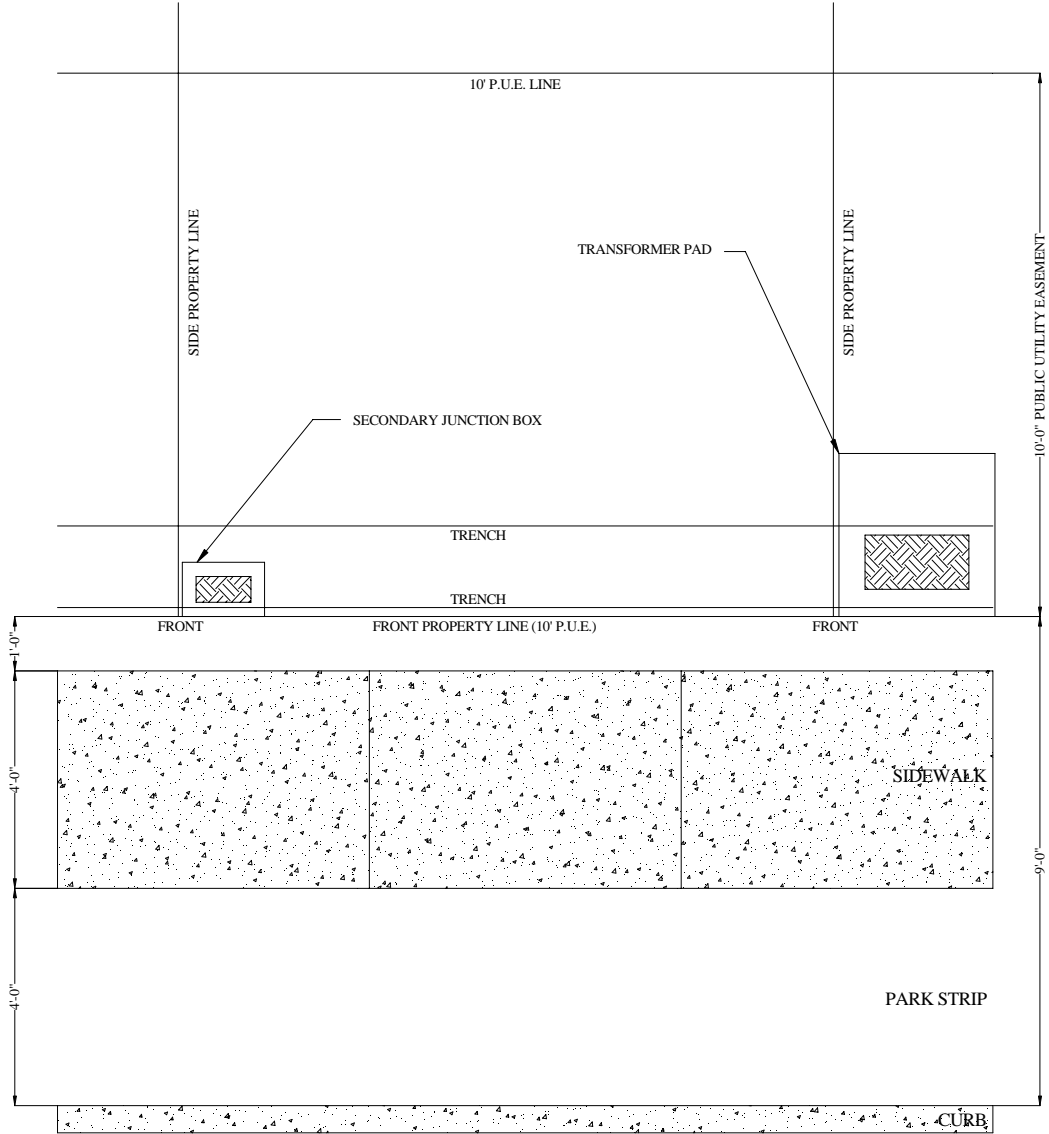

**Notes:**

1. Transformers and secondary junction boxes to be offset from the property line on either side.
2. Transformers and secondary junction boxes to be located as per the electrical design provided to Salem City.
3. Transformer and other equipment must be installed so that the front faces the sidewalk. No obstructions are allowed in from the Salem City Power equipment.
4. Spare conduit shall be capped 2" above final grade

**SALEM CITY POWER  
ELECTRICAL REQUIREMENTS  
& STANDARDS MANUAL  
PAD MTD. TRANSFORMER**

ELECTRIC 5.1
PAD MTD. TRANSFORMER
SCALE: NONE
DATE: 8.29.07
REV:
REV DATE:

# Single Phase Transformer Pad or Secondary Junction Box Location with Sidewalk and Planter

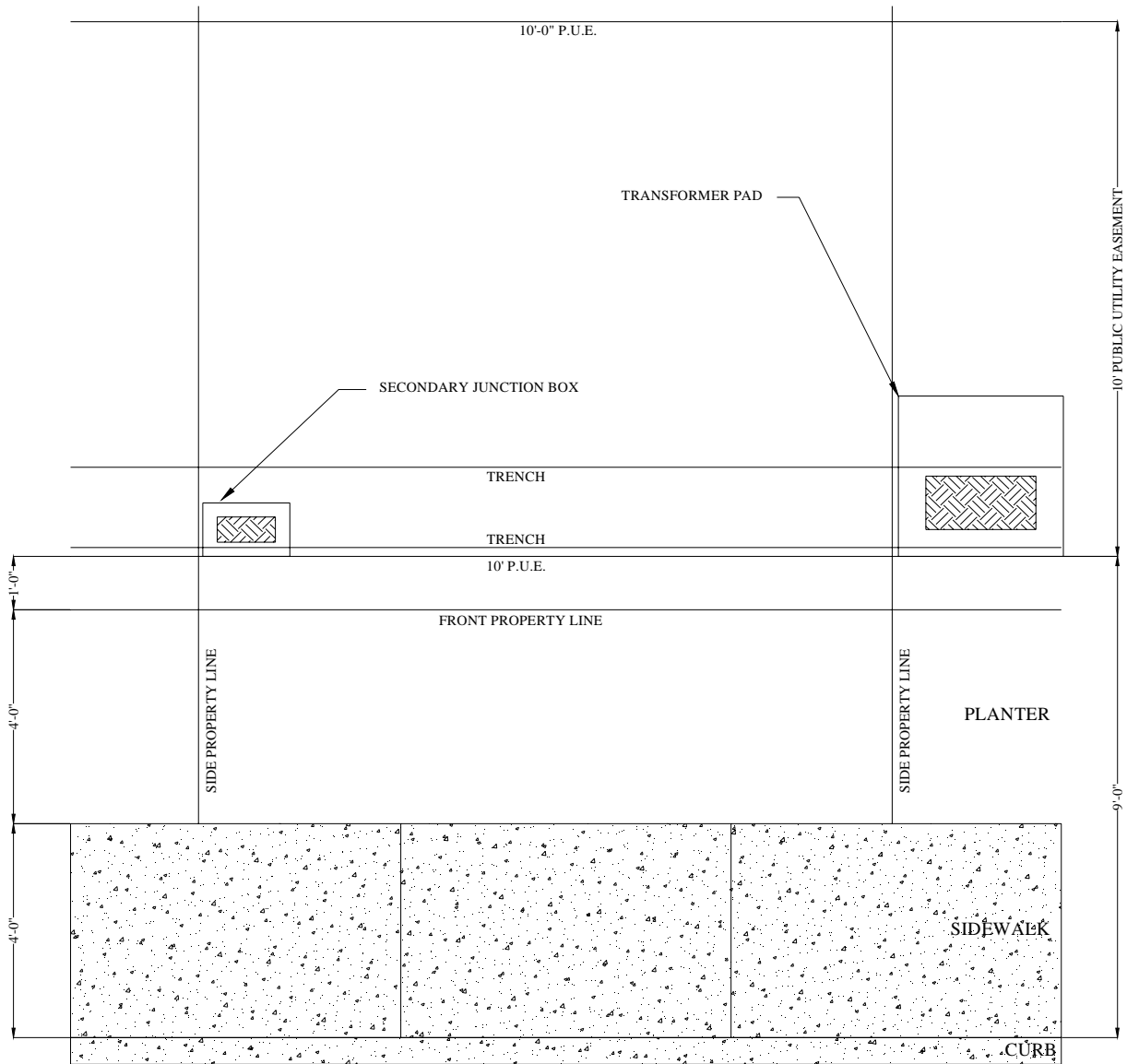

**Notes:**

1. Transformers and secondary junction boxes to be offset from the property line on either side.
2. Transformers and secondary junction boxes to be located as per the electrical design provided to Salem City.
3. Transformer and other equipment must be installed so that the front faces the sidewalk. No obstructions are allowed in from the Salem City Power equipment.
4. Spare conduit shall be capped 2" above final grade

**SALEM CITY POWER  
ELECTRICAL REQUIREMENTS  
& STANDARDS MANUAL  
PAD MTD. TRANSFORMER**

ELECTRIC 5.2
PAD MTD. TRANSFORMER
SCALE: NONE
DATE: 8.29.07
REV:
REV DATE:



# Single Phase Transformer Pad or Secondary Junction Box Location with Sidewalk and No Planter

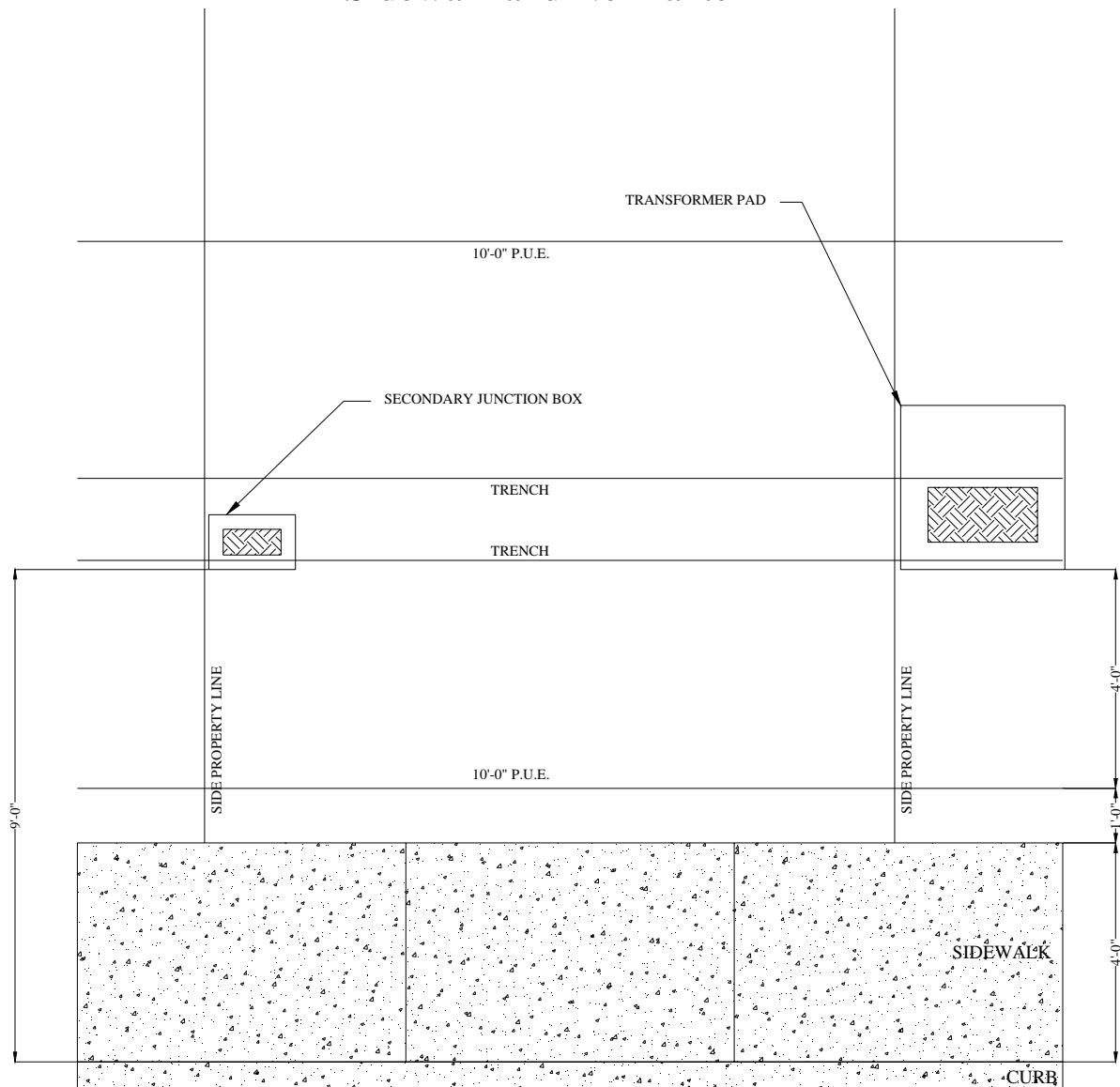

**Notes:**

1. Transformers and secondary junction boxes to be offset from the property line on either side.
2. Transformers and secondary junction boxes to be located as per the electrical design provided to Salem City.
3. Transformer and other equipment must be installed so that the front faces the sidewalk. No obstructions are allowed in from the Salem City Power equipment.
4. Spare conduit shall be capped 2" above final grade

**SALEM CITY POWER  
ELECTRICAL REQUIREMENTS  
& STANDARDS MANUAL  
PAD MTD. TRANSFORMER**

ELECTRIC 5.3
PAD MTD. TRANSFORMER
SCALE: NONE
DATE: 8.29.07
REV:
REV DATE:

# Single-Phase and Three-Phase Pad Mounted Transformer Clearances

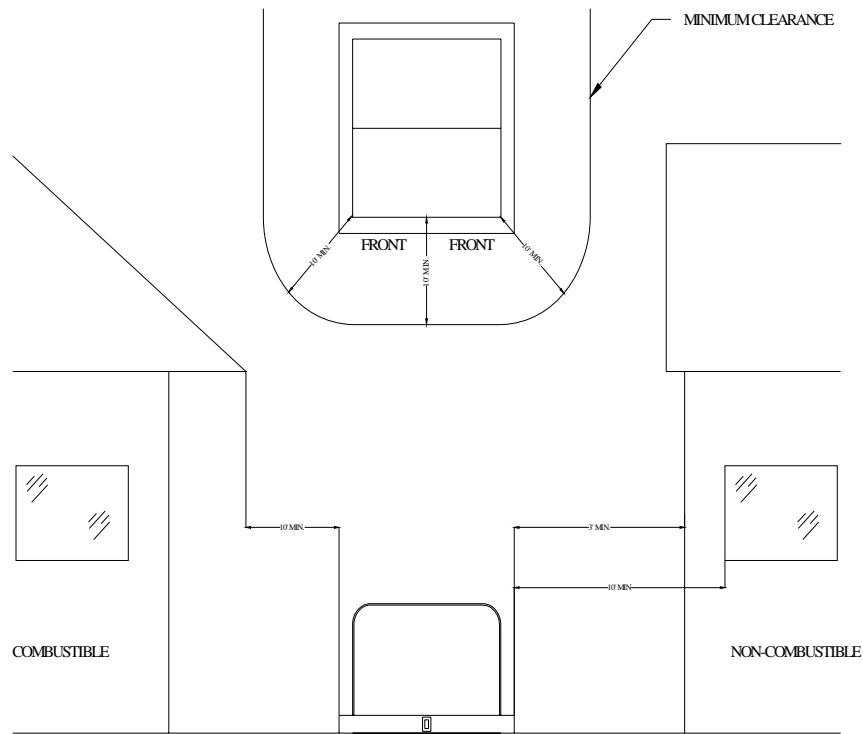

- 10 foot clear area in front of equipment to allow for the use of hot sticks (Note 2)
- 10 foot clearance from any transformer surface if structure is of combustible material
- 3 foot clearance to any non-combustible building surfaces that do not have any openings closer than 10 feet

**Notes:**

1. Consult National Electric Safety Code, NEC, state, and local building and fire codes for additional requirements.
2. The front of pad mounted transformers must be located away from building walls or other barriers to allow for safe working practices.
3. Consult the Salem Power Department for additional clearances that may be required for doors, windows, fire escapes, air vents, etc.
4. When pad mounted transformers or other equipment are installed where they may be struck by a motorized vehicle the customer will install and maintain Salem Power Department approved barrier posts to protect the equipment.

**SALEM CITY POWER  
ELECTRICAL REQUIREMENTS  
& STANDARDS MANUAL  
PAD MTD. TRANSFORMER**

ELECTRIC 5.4
PAD MTD. TRANSFORMER
SCALE: NONE
DATE: 8.29.07
REV:
REV DATE:

# Equipment Erosion Prevention

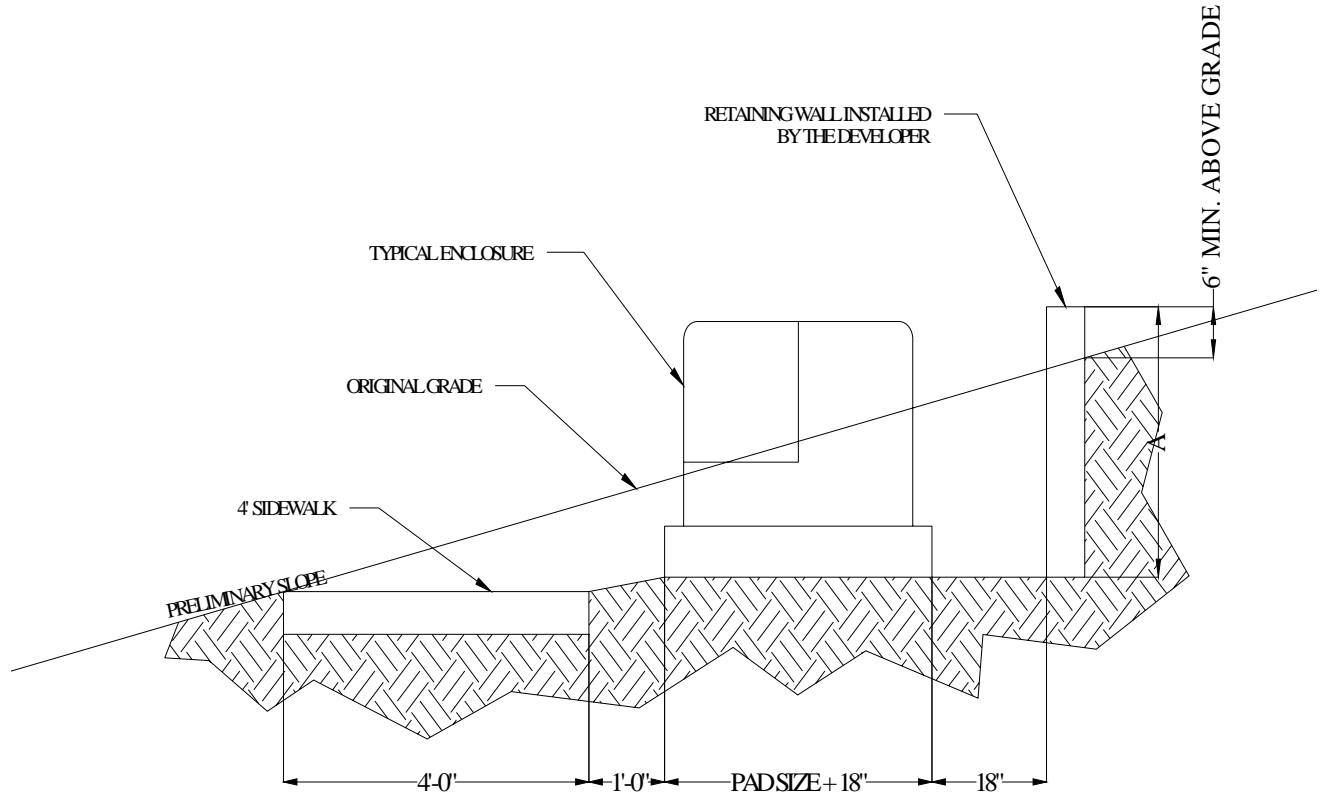

**Notes:**

1. When it becomes necessary to notch out or fill a slope to install an enclosure or transformer, the cleared area should be sufficient size to accommodate the enclosure. The front of the pad shall be placed 2 inches maximum above the sidewalk.
2. The area under and behind the pad must be level and compacted as per trench specifications.
3. A retaining wall is required if dimension "A" is greater than 12 inches.
4. Side retaining walls are also required if dimension "A" is greater than 18 inches. The retaining wall shall be 6 inches above existing grade and 18 inches from each side and the back of the enclosure
5. All grading shall be performed by the developer.
6. Contact the Salem Power Department if assistance is required.

**SALEM CITY POWER  
ELECTRICAL REQUIREMENTS  
& STANDARDS MANUAL  
PAD MTD. TRANSFORMER**

ELECTRIC 5.5
PAD MTD. TRANSFORMER
SCALE: NONE
DATE: 8.29.07
REV:
REV DATE:

# Single-Phase Pad Mounted Transformer

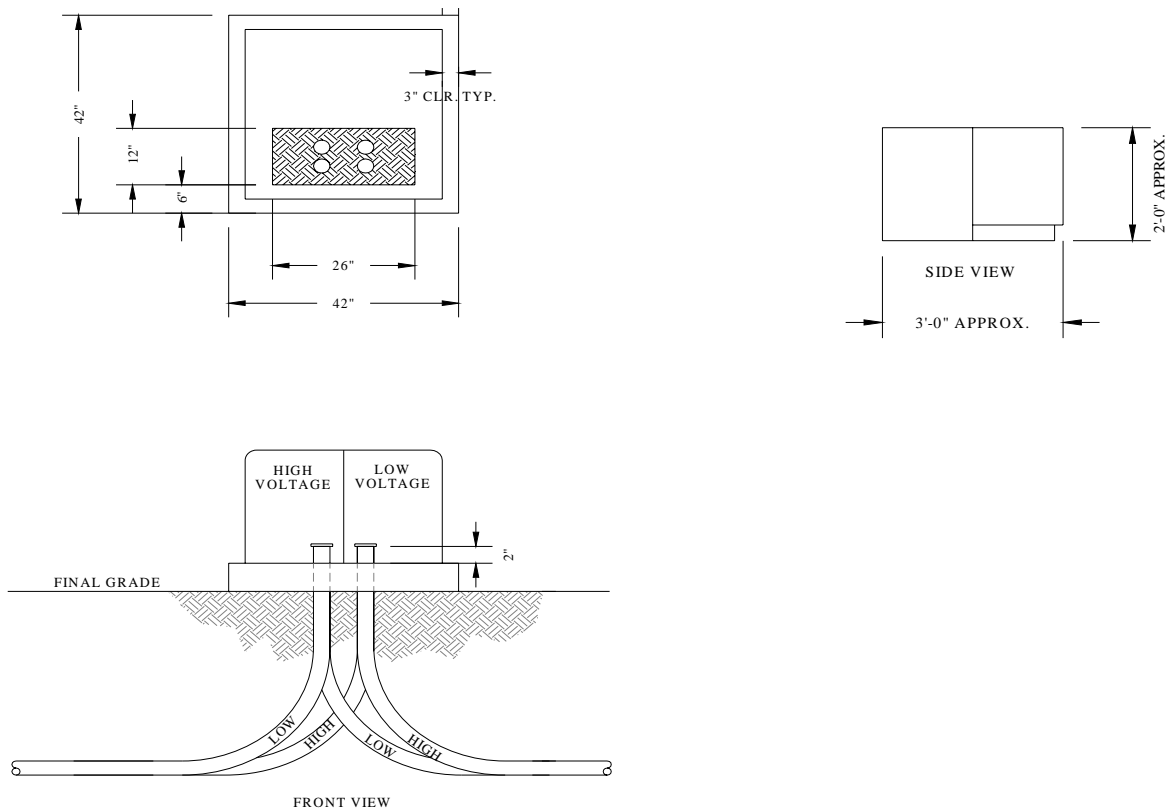

**Notes:**

1. The developer will supply transformer pads, ground rods and conduit.
2. The Salem City Power Department will supply transformers and conductors.
3. A concrete transformer pad may be substituted with an approved prefabricated concast pad.
4. A conduit bonding bushing is required on all metallic conduit. The bonding bushing must be properly grounded with 2/0 Cu.
5. Fill material under the concrete pad or base shall be road base meeting state specifications and shall be compacted to 95%. Road base fill shall extend from the bottom of the trench to the transformer pad and shall extend 3 inches on the front, sides and back.

**SALEM CITY POWER  
ELECTRICAL REQUIREMENTS  
& STANDARDS MANUAL  
PAD MTD. TRANSFORMER**

ELECTRIC 5.6
PAD MTD. TRANSFORMER
SCALE: NONE
DATE: 8.29.07
REV:
REV DATE:

# THREE-PHASE TRANSFORMER CONCRETE PAD WITHOUT CT RACK

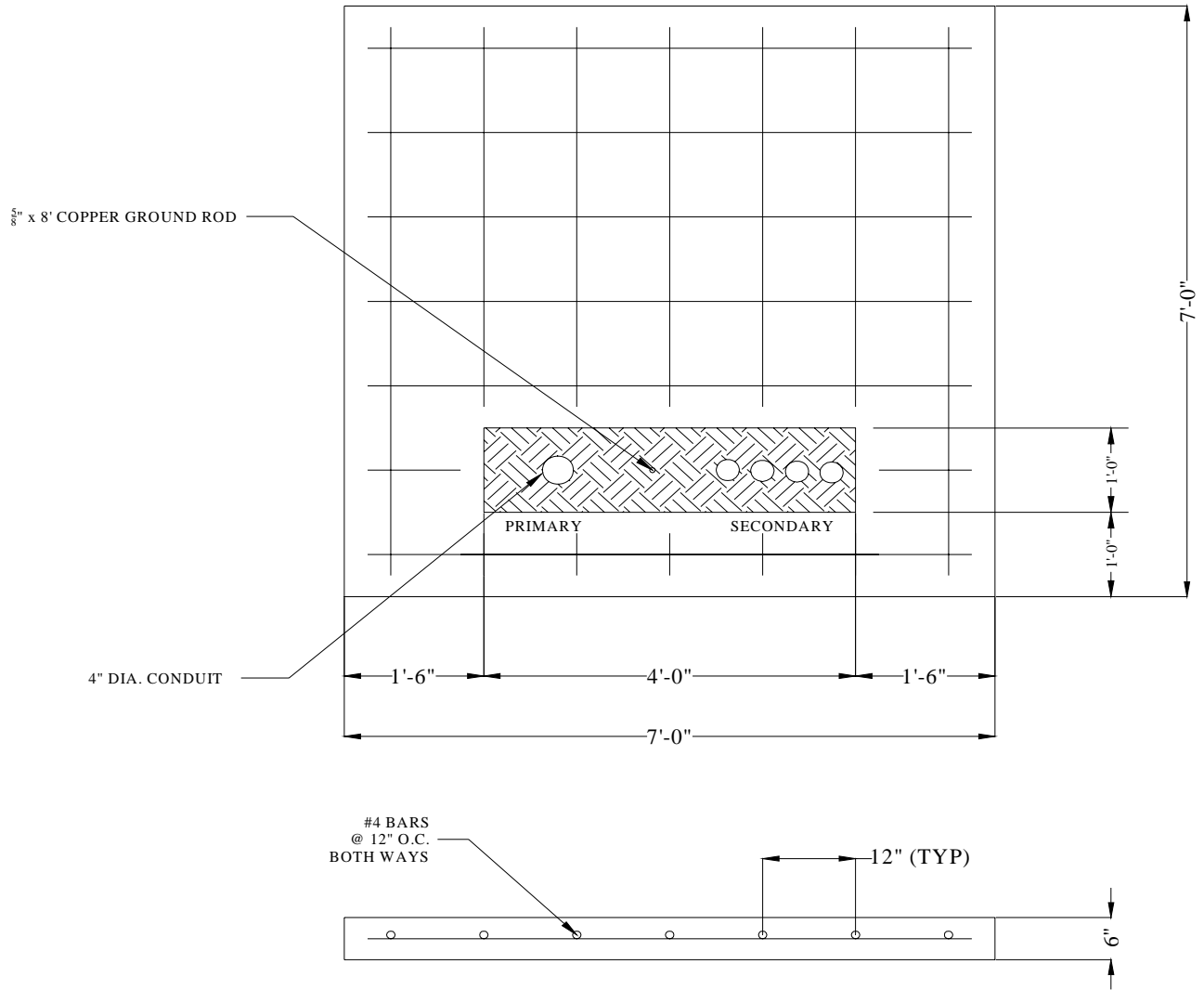

**SALEM CITY POWER  
ELECTRICAL REQUIREMENTS  
& STANDARDS MANUAL  
PAD MTD. TRANSFORMER**

ELECTRIC 5.7
PAD MTD. TRANSFORMER
SCALE: NONE
DATE: 8.29.07
REV:
REV DATE:

# THREE-PHASE TRANSFORMER PAD WITH METERING STATION

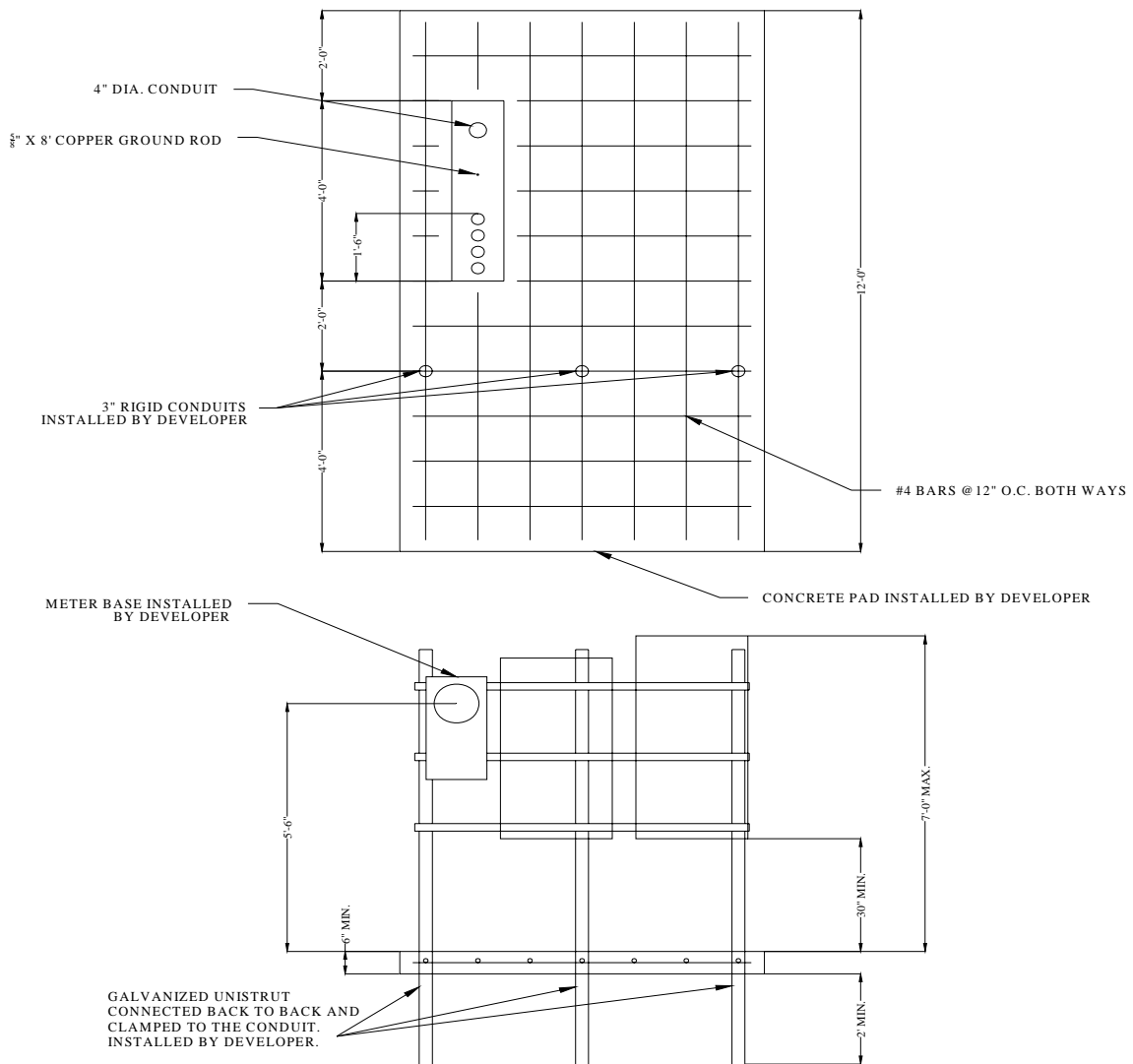

**Notes:**

1. Salem City will not pull or terminate commercial services from the secondary side of the transformer.
2. The developer shall terminate all cables from the CT cans in.
3. The contractor shall terminate all cables they run and provide lugs for the transformer secondary.

## SALEM CITY POWER ELECTRICAL REQUIREMENTS & STANDARDS MANUAL PAD MTD. TRANSFORMER

ELECTRIC 5.8
PAD MTD. TRANSFORMER
SCALE: NONE
DATE: 8.29.07
REV:
REV DATE:

# STREET LIGHTING

## General

The following general requirements shall apply to street lights installed in new underground residential subdivisions/developments (subdivisions) located within the service area of Salem City Power (within Salem City):

Salem City Power will provide electric power for street lights at no cost, except as otherwise provided below in the Street Light Layouts section.

Salem City Power standard (Town and Country) street lights (poles, fixtures and wiring) shall be used except as provided in item 5, and 6 below. The standard street light pole (direct embedded) is a W.J. Whatley, Inc. Catalog No. E3020-20-60-N1,3 and the standard fixture (pole top mounted) is a Cooper Lighting Catalog No. LXF10SR2334 (100 watt high pressure sodium lamp) or approved General Electric equal.

Salem City Power standard street lights will be installed in accordance with Salem City Power's Line Extension Policy.

Salem City Power standard street lighting will be installed, owned and maintained by the Salem City Power. Conduit systems for street lighting wiring shall be installed by contractors/developers in accordance with Drawing E.6.4.

Development specific decorative (non Salem City Power standard) street lighting (poles, fixtures and wiring) may be installed in subdivisions with homeowners associations.

Decorative lighting (service disconnect, poles, luminaries, lamps, conduit and wiring) installed in underground subdivisions with homeowners associations shall be installed by contractors/developers, and owned by the homeowners associations. Power for the street lights will be provided by Salem City Power in accordance with item 1 above.

## Street Light Layouts

The following layout requirements shall apply to Salem City Power standard and decorative street lighting installations:

Layouts for Salem City Power standard street light installations will be prepared by Salem City Power.

Layouts for decorative street light installations shall be prepared by contractors/developers, utilizing the general requirements included subsequently in this section. Contractors/developers shall provide drawings of proposed layouts for decorative street lighting to Salem City Power for

	<b>SALEM CITY POWER ELECTRICAL REQUIREMENTS &amp; STANDARDS MANUAL STREET LIGHTING</b>	ELECTRIC 6.1
		STREET LIGHTING
		SCALE: NONE
		DATE: 8.29.07
		REV:
		REV DATE:

review and approval. Catalog information on the poles, luminaries and lamps proposed for use shall be provided by contractors/developers with the light layouts.

In general, street lights shall be placed at three and four way intersections, and at 90 degree turns (elbows). See Drawing E.6.3 for typical street lighting layout.

Street lights shall also be installed between intersections at staggered spacings of approximately 400 feet. Decorative street lights may be installed at lesser spacings, but homeowners associations will be billed for the electric power usage of the additional lights. See Drawing E.6.3 for typical street lighting layout.

Decorative street lights may be installed (400 foot non-staggered spacing) on medians (islands) in streets with islands at least 10 feet in width. Decorative street lights may be installed at lesser spacings, but homeowners associations will be billed for the electric power usage of the additional lights.

Luminaries for decorative street lights shall be Type III, include a photo cell receptacle and shall be suitable for use with a 100 watt high pressure sodium lamp. Use of luminaries with higher wattage lamps or other light sources (metal halide or mercury vapor) must be approved by Salem City Power. Additional charges for excess electric power usage may be assessed to homeowners associations. House side shields shall be provided if required. Street light poles shall provide a minimum mounting height for luminaries of 16 feet.

#### **Point(s) of Delivery for Decorative Lighting**

The point(s) of delivery for decorative street lights shall be at a location(s) approved by Salem City Power. Contractors/developers shall provide drawings of proposed locations for points of delivery for decorative street lighting to the Salem City Power for review and approval. These points of delivery shall typically be proximate to Salem City Power owned pad mounted transformers or secondary junction boxes. The layout of decorative lights shall be so as to minimize the number of delivery points required.

All points of delivery for decorative street lights shall include a disconnect with over current protective device(s) [fuse(s) or breaker(s)]. The rating of the over current protection shall be compatible with the current rating of the wiring connected to the device. The disconnect shall be service entrance rated, tamper proof, equipped with provisions for locking, installed in a NEMA 3R enclosure and mounted on a building wall, or substantial wood or steel post. The disconnect and appurtenant facilities shall be installed in accordance with the applicable articles of the National Electric Code (NEC).

Facilities installed at decorative street light points of delivery shall be inspected by the Salem City electrical inspector prior to connection to the Salem City Power electrical system.

	<b>SALEM CITY POWER ELECTRICAL REQUIREMENTS &amp; STANDARDS MANUAL STREET LIGHTING</b>	ELECTRIC 6.2
		STREET LIGHTING
		SCALE: NONE
		DATE: 8.29.07
		REV:
		REV DATE:



Wiring between Salem City Power pad mounting transformers or secondary junction boxes and disconnects for decorative lighting will be installed, owned and maintained by Salem City Power and installed in conduits (source side conduit systems) provided (furnished and installed) by contractors/developers (reference paragraph D of this section). Salem City Power will own and maintain the source side conduits after the street light installation is completed.

**Conduit for Salem City Power Standard and Decorative Street Lights**

Salem City Power wiring for Salem City Power standard and decorative street lights shall be installed in direct buried conduit.

**Salem City Power Standard Street Lights:**

Contractors/developers shall provide (purchase and install) all street lighting conduit systems (conduit, fitting, elbows, conduit cement, etc.) for Salem City Power standard street lights. Salem City Power will own and maintain the conduit systems after the street light installation is completed. The conduit systems shall extend from Salem City Power pad mounted transformers or secondary junction boxes to street light locations. The contractor/developer shall be responsible for proper routing and placement (burial depth, excavation, bedding, backfill and compaction) of conduits, and for the location of conduit end points (stubs ups) at pad mounted transformers and/or secondary junction boxes, and street light locations.

**Decorative Street Lights:**

Contractors/developers shall provide (purchase and install) source side conduit systems between decorative street light delivery points and Salem City Power pad mounted transformers and/or secondary junction boxes. Salem City Power will own and maintain the source side conduit systems after the street light installation is completed. The contractor/developer shall be responsible for proper routing and placement of conduits, and for the location of conduit end points (stubs ups) at pad mounted transformer and/or secondary junction box locations. The contractors/developers shall also be responsible for terminating the conduit at the line side of the disconnecting means at delivery points. Salem City Power will install the wiring from transformer or secondary junction box to the delivery point and terminate the wiring at the source of the disconnect.

Conduit types and capping shall be in accordance with the conduits paragraphs of this document.

**STREET LIGHTING CONDUIT REQUIREMENTS**

The contractor/developer shall be responsible for the installation of street lighting conduit systems (2 inch diameter) extending from transformer or secondary junction boxes to lighting fixture locations. Light fixtures should be located at street intersections where possible. There should be no more than 400 feet between lights. See drawing E.6.4 for a typical street lighting layout. The contractor is responsible for proper location and centering of conduit end points for

**SALEM CITY POWER  
ELECTRICAL REQUIREMENTS  
& STANDARDS MANUAL  
STREET LIGHTING**

ELECTRIC 6.3
STREET LIGHTING
SCALE: NONE
DATE: 8.29.07
REV:
REV DATE:

lighting fixture installations. The City, under the terms of its Line Extension Policy, shall furnish and install lighting fixtures and light fixture service cables. Commercial areas shall be required to place conduit to light city streets bordering their development. Lights shall be paid for by the Developer and installed by the Power Department. Light placement shall be at each intersections and one for every 150 feet as approved by the Power Department. Light type and size shall be determined by the Power Department according to road size and area.

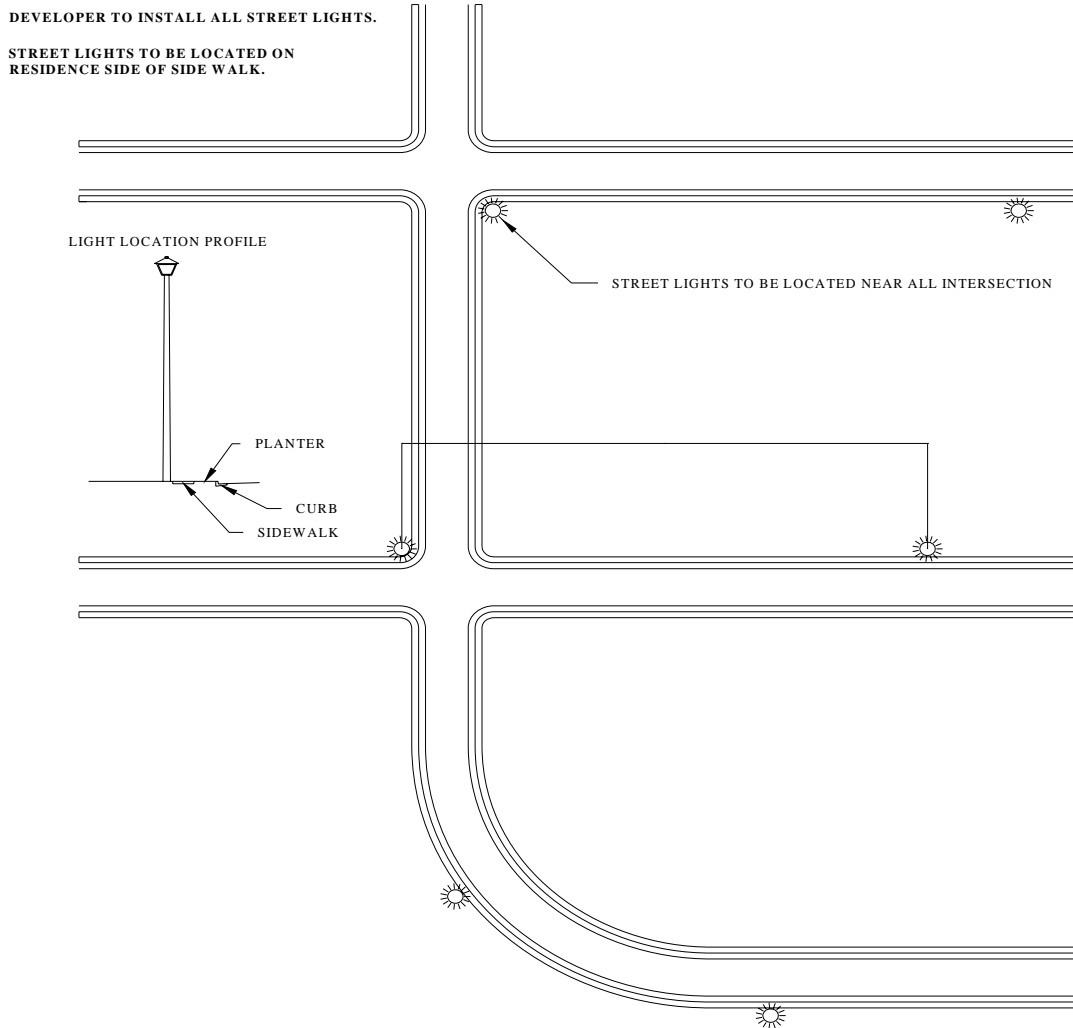

Notes:

1. Lighting design and layout shall be provided by Salem City.
2. Inspection of street lighting shall be scheduled at the same time as the depth of system and compaction inspections.

Figure 1 – Typical Street Lighting Layout

**SALEM CITY POWER  
ELECTRICAL REQUIREMENTS  
& STANDARDS MANUAL  
STREET LIGHTING**

ELECTRIC 6.4
STREET LIGHTING
SCALE: NONE
DATE: 8.29.07
REV:
REV DATE:

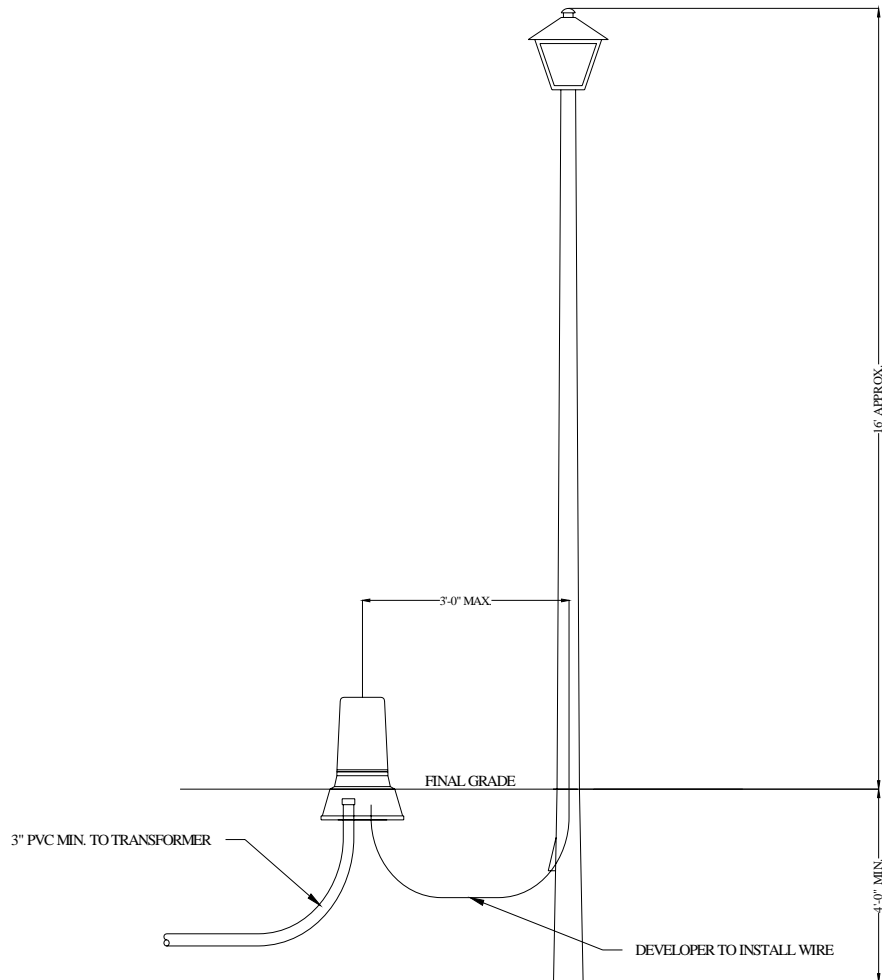

Notes:

1. The developer will provide 3 inch conduit from the transformer to the secondary junction box.
2. Salem City Power will provide lockable secondary junction boxes and wire from the secondary junction box to the light pole.

Figure 2 – Street Light Wiring

**SALEM CITY POWER  
ELECTRICAL REQUIREMENTS  
& STANDARDS MANUAL  
STREET LIGHTING**

ELECTRIC 6.5
STREET LIGHTING
SCALE: NONE
DATE: 8.29.07
REV:
REV DATE:

# Conduit Placement for Sectionalizers

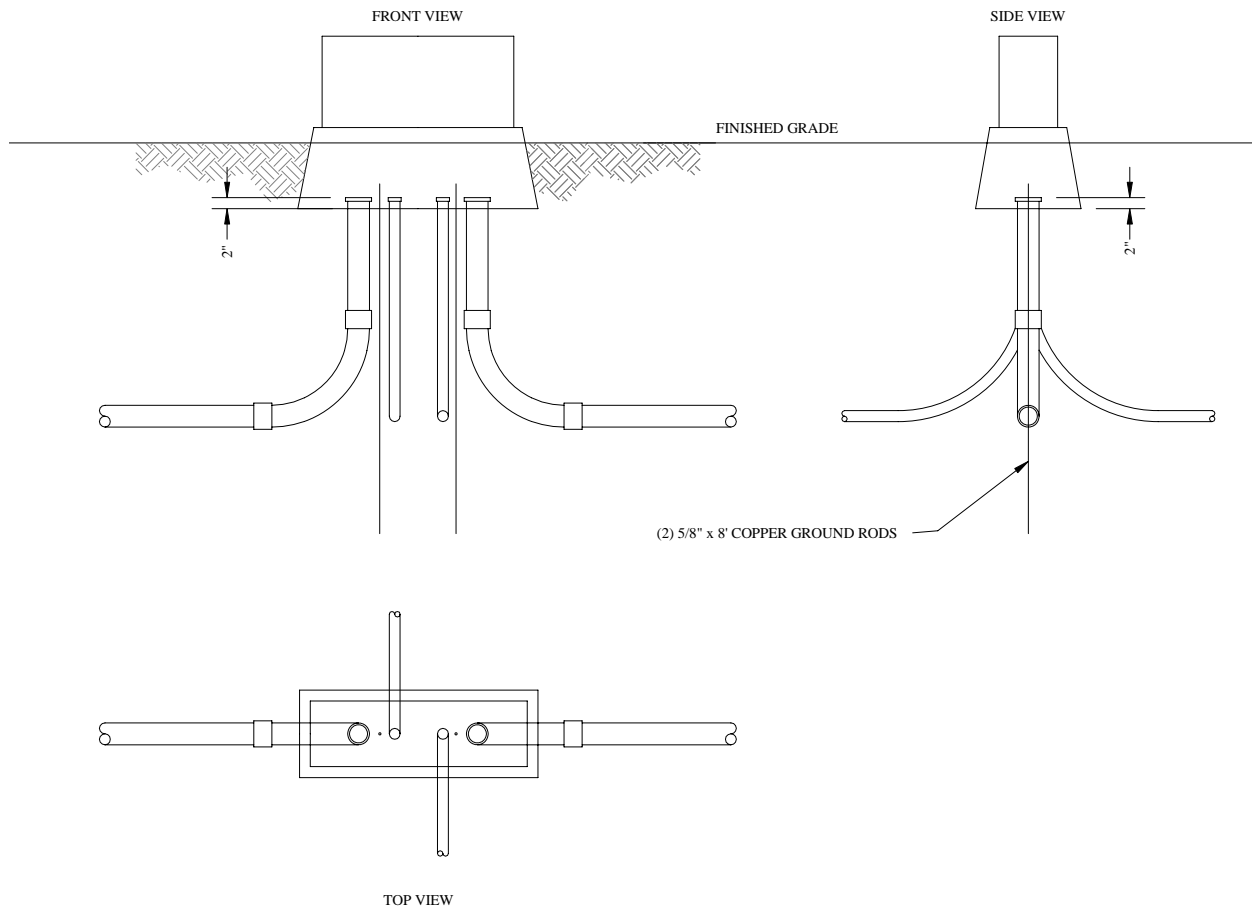

## Notes:

1. All 90 degree elbows shall be rigid steel and PVC wrapped.
2. Junction boxes and bases will be provided by Salem City and installed by the developer.
3. The developer shall provide all ground rods and subsequent materials to complete the installation.
4. Conduit sizes and locations will be provided by Salem City on the subdivision electrical plans.
5. Support all conduits during backfilling keeping them as vertical as possible.

**SALEM CITY POWER  
ELECTRICAL REQUIREMENTS  
& STANDARDS MANUAL  
SECTIONALIZERS & SWITCHES**

ELECTRIC 7.1
SECTIONALIZERS & SWITCHES
SCALE: NONE
DATE: 8.29.07
REV:
REV DATE:

# Conduit Placement for Switches

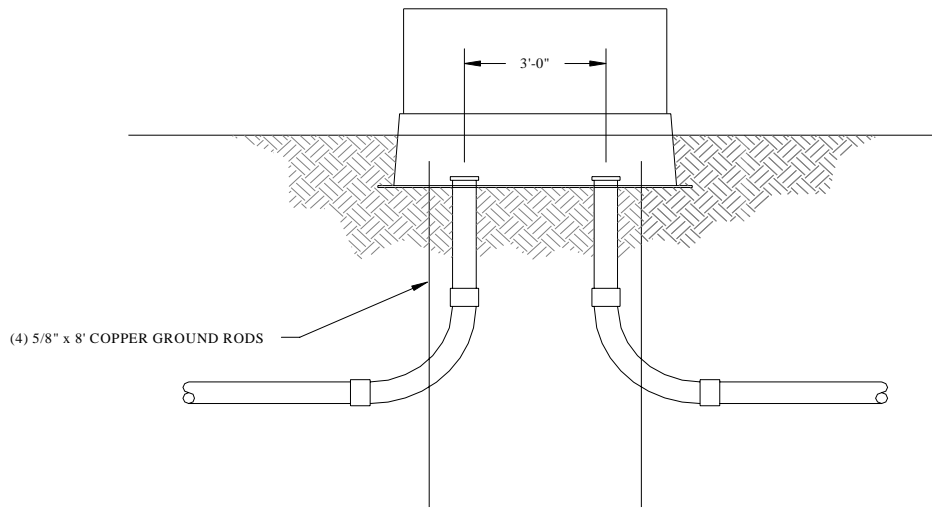
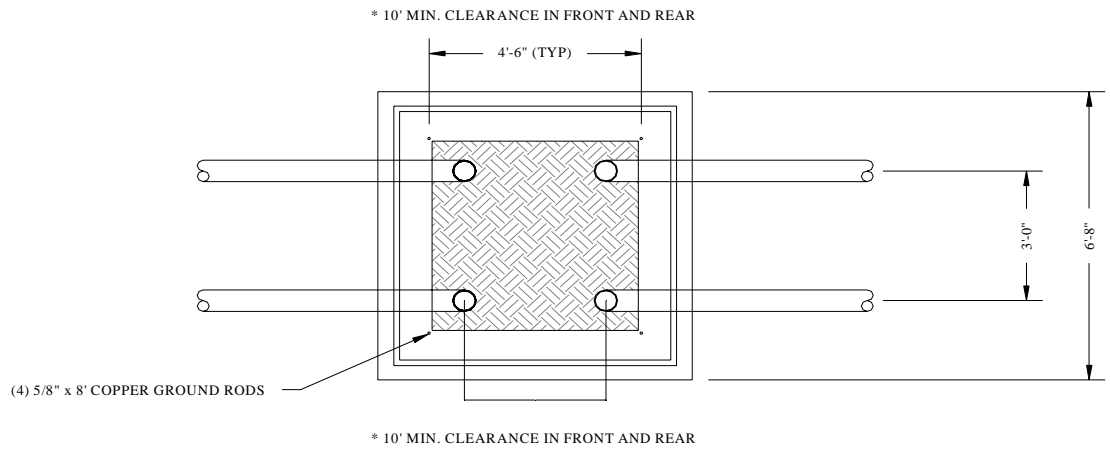

**Notes:**

1. All 90 degree elbows shall be rigid steel and PVC wrapped.
2. Switchgear and bases will be provided by Salem City and installed by the developer.
3. The developer shall provide all ground rods and subsequent materials to complete the installation.
4. Conduit sizes and locations will be provided by Salem City on the subdivision electrical plans.
5. Support all conduits during backfilling keeping them as vertical as possible.

**SALEM CITY POWER  
ELECTRICAL REQUIREMENTS  
& STANDARDS MANUAL  
SECTIONALIZERS & SWITCHES**

ELECTRIC 7.2
SECTIONALIZERS & SWITCHES
SCALE: NONE
DATE: 8.29.07
REV:
REV DATE: